

B-B (1:1)

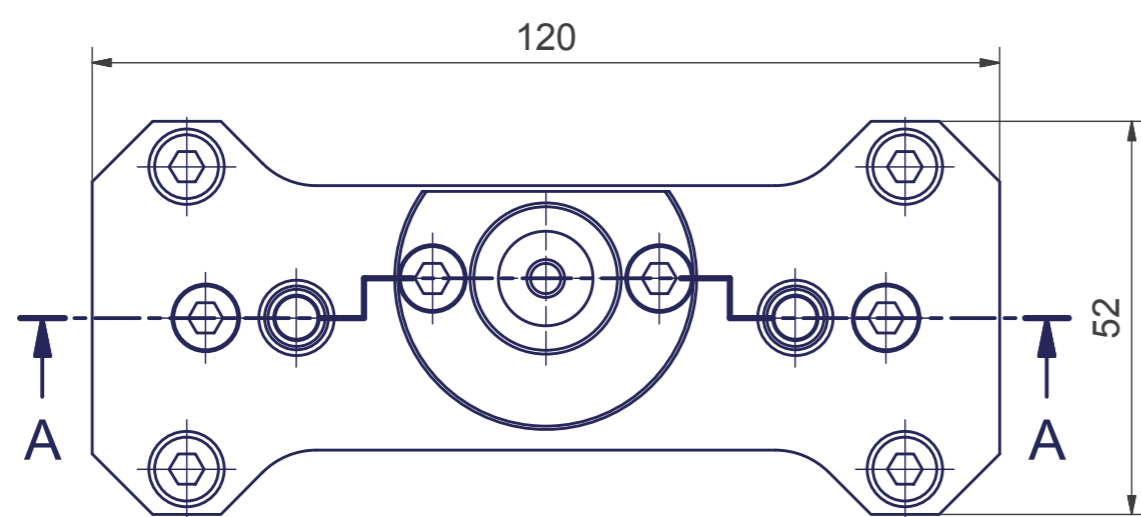

A-A (1:1)

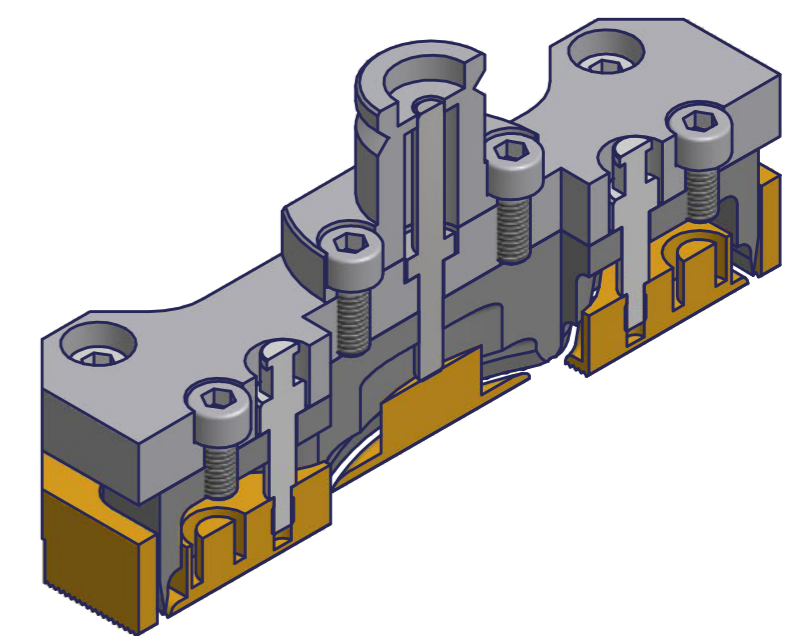
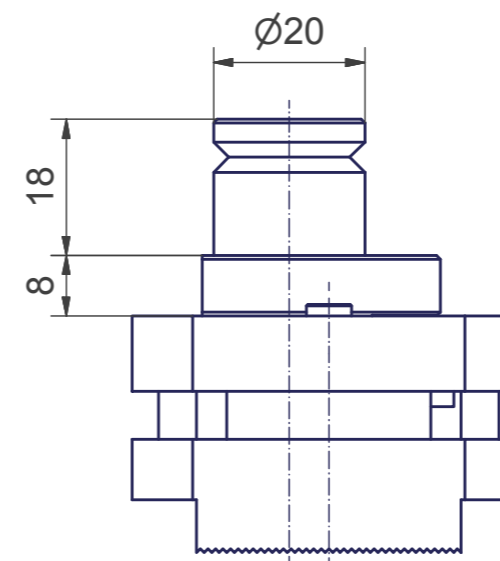
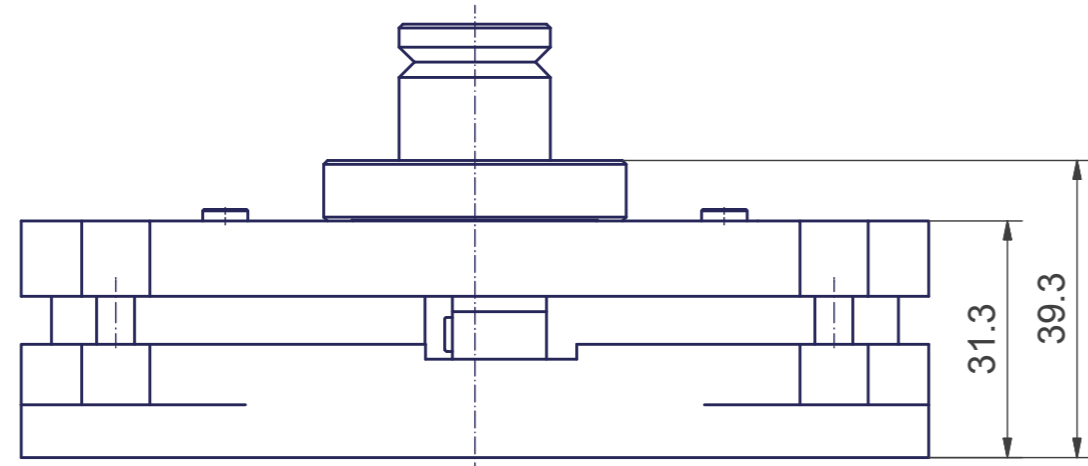
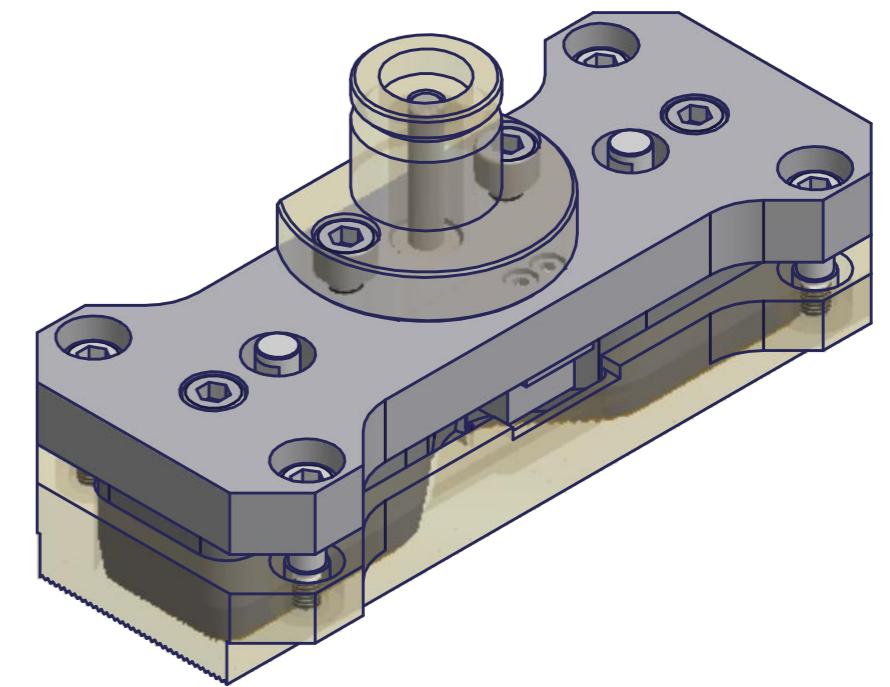
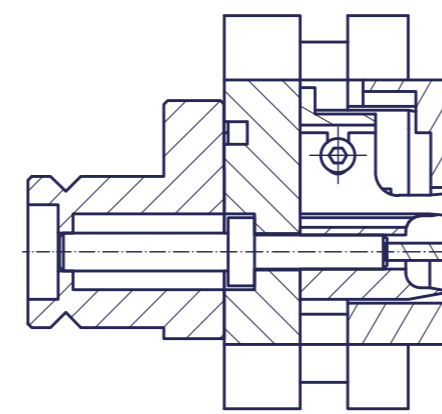
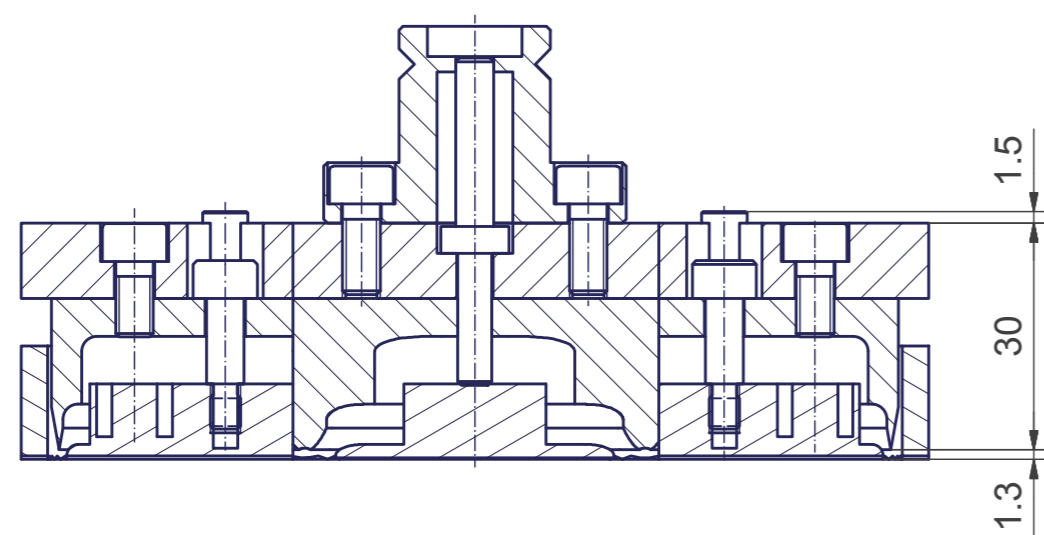

Schutzvermerk nach DIN 34 beachten		Tolerierung ISO 8015		Maßstab: 1:1		Masse:	
				Werkstoff:			
				Halbzeug:			
				Rohteil-Nr.:			
		Datum: 11.09.2009		Name: orothenaicher		<b>Stanzeinheit ASTM D624B</b>	
						Ritzmesser fix einstellbar	
						Prüfkörper ASTM D624B / DIN ISO 34-1	
				CAD/CAM/CAE		STAM.01.05.03.00	
				Büro für CA-Technik		Blatt 1	
				Otto Rothenaicher		1 Bl	
				Ers. f.:		Ers. d.:	
				Dateiname: SMWA03 Schlitz fix.iam		A2	
Zust.	Anderungen	Datum	Name				