

A-A (1:1)

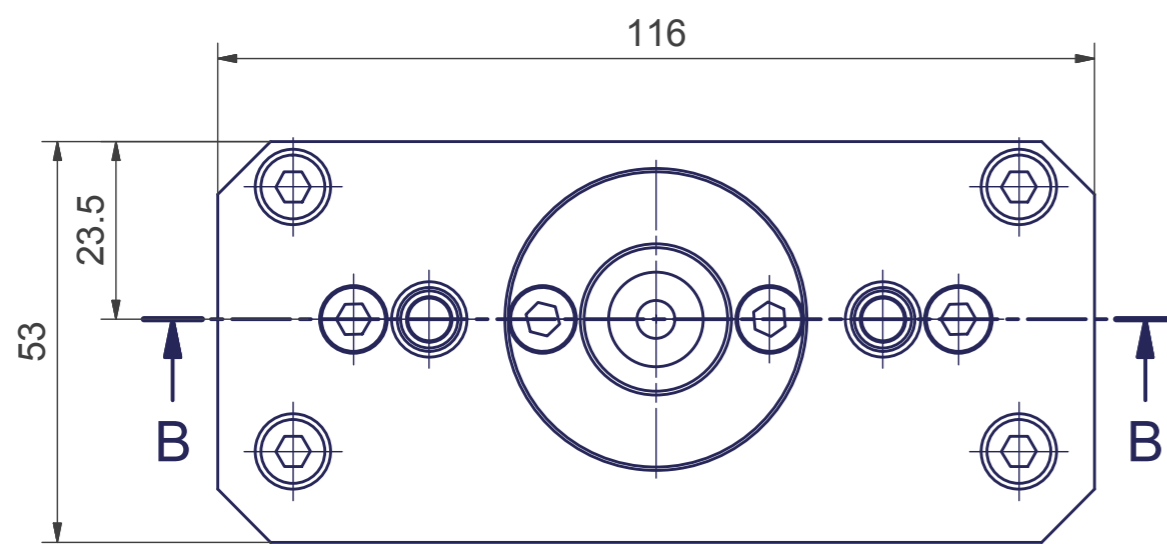

B-B (1:1)

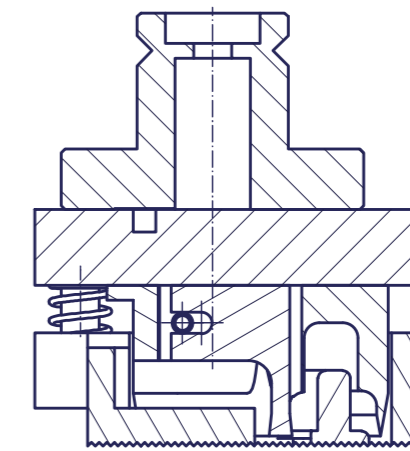
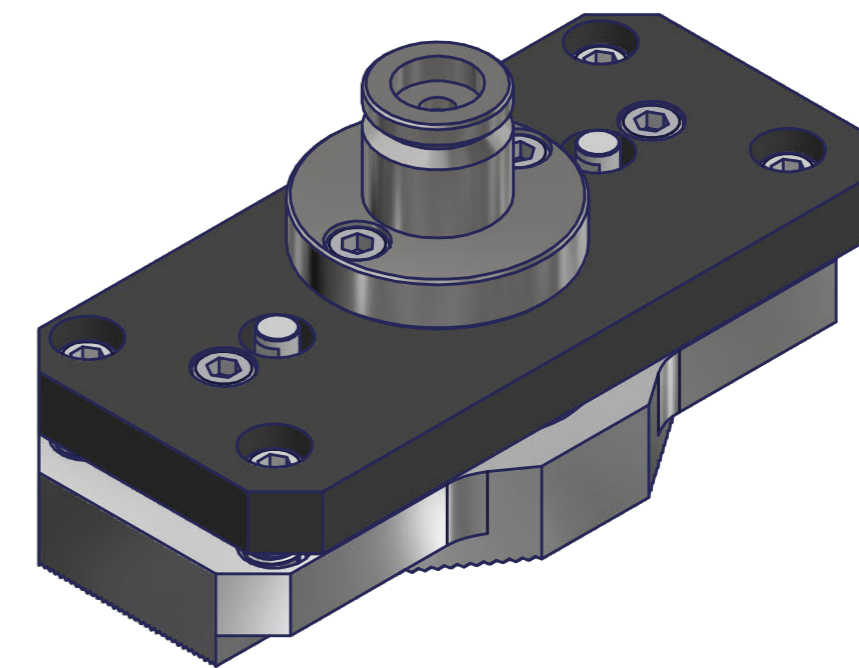
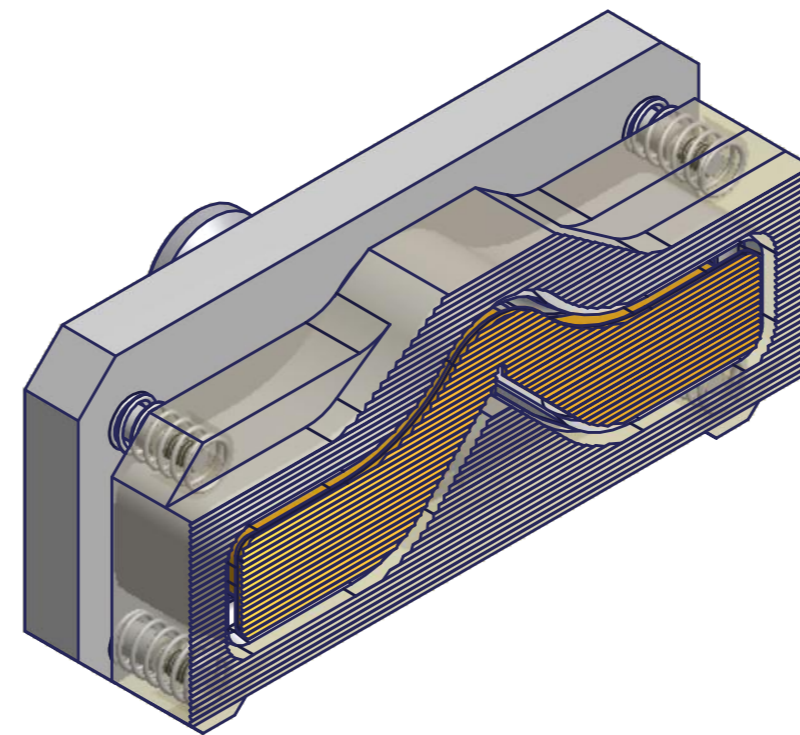
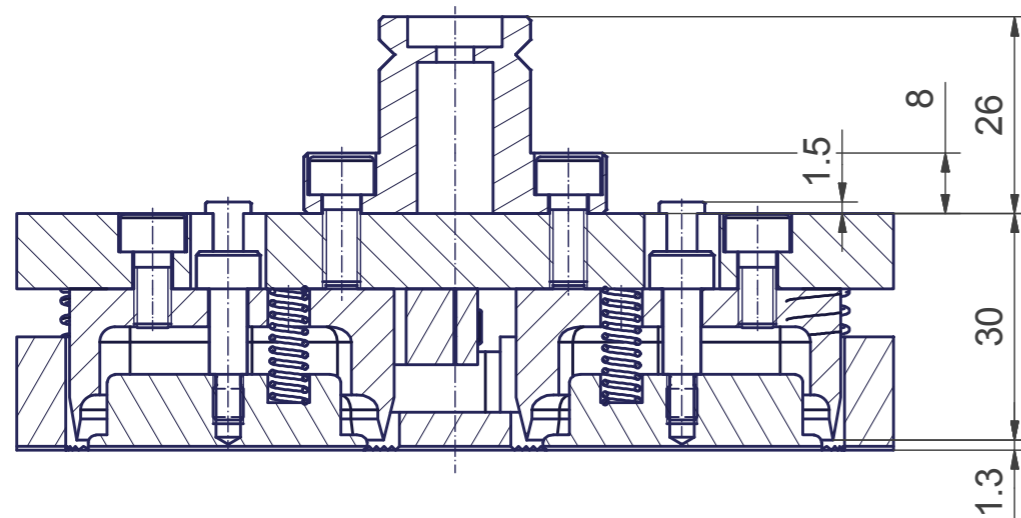

Schutzvermerk nach DIN 34 beachten		Tolerierung ISO 8015		Maßstab: 1:1		Masse:	
				Werkstoff:			
				Halbzeug:			
				Rohteil-Nr.:			
		Datum		Name		Stanzmesser-Einheit G01 Ritzmesser fix 1 mm Prüfkörper DIN ISO 34-1 Winkelprobe	
		Gez. 09.01.2008		orothenäicher			
		Gepr.					
		Norm					
						STAM.01.06.03.00 Blatt 1	
				Büro für CA-Technik Otto Rothenäicher		St.-Nr.: STAM.01.06.03.00 1 Bl.	
						Ers. f.: Ers. d.: A2	
						Dateiname: Stanzmessereinheit G01 fix.iam	
Zust.	Anderungen	Datum	Name				