

B-B (1:1)

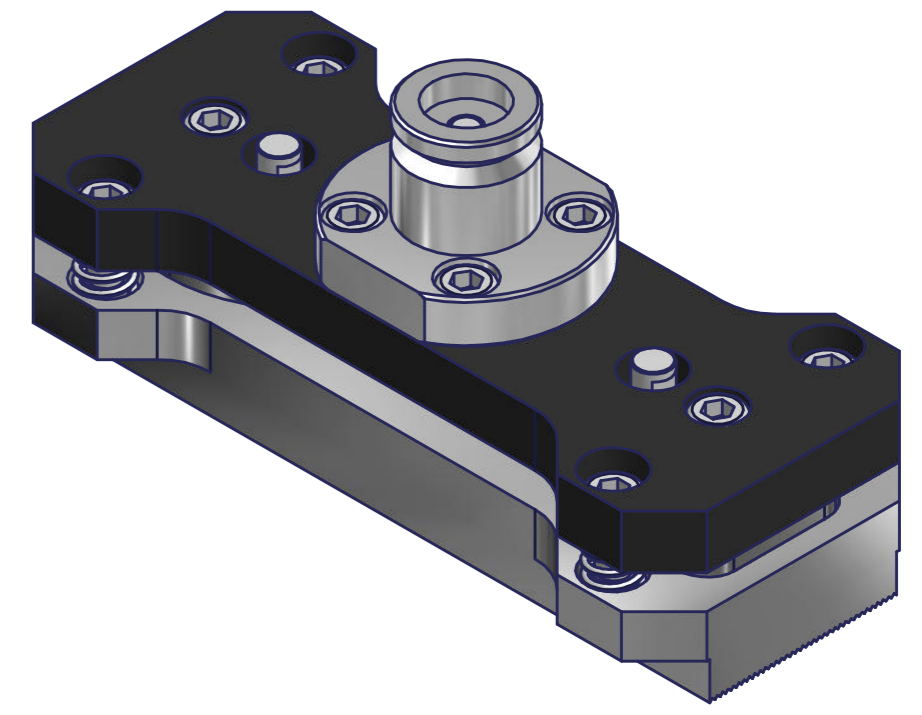
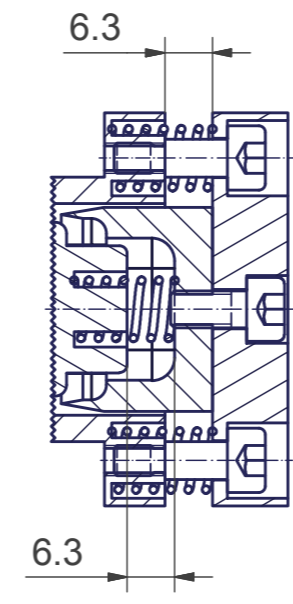

Schutzvermerk nach DIN 34 beachten		Tolerierung ISO 8015		Maßstab: Werkstoff: Halbzeug: Rohteil-Nr.:	
		Datum: 11.09.2009 Name: Ro		Stanzmesser-Einheit S1 31.3xs52x126 Normstab S1 DIN 53504 Stanzmesser-Einheit STAM.01.01	
		Büro für CA-Technik Otto Rothenaicher		STAM.01.01.01.00 Blatt 1	
				St.-Nr.: STAM.01.01.01.00 1 Bl.	
				Ers. f.: Ers. d.: A2	
				Dateiname: Stanzmesser-Einheit S101.iam	