

A-A (1:1)

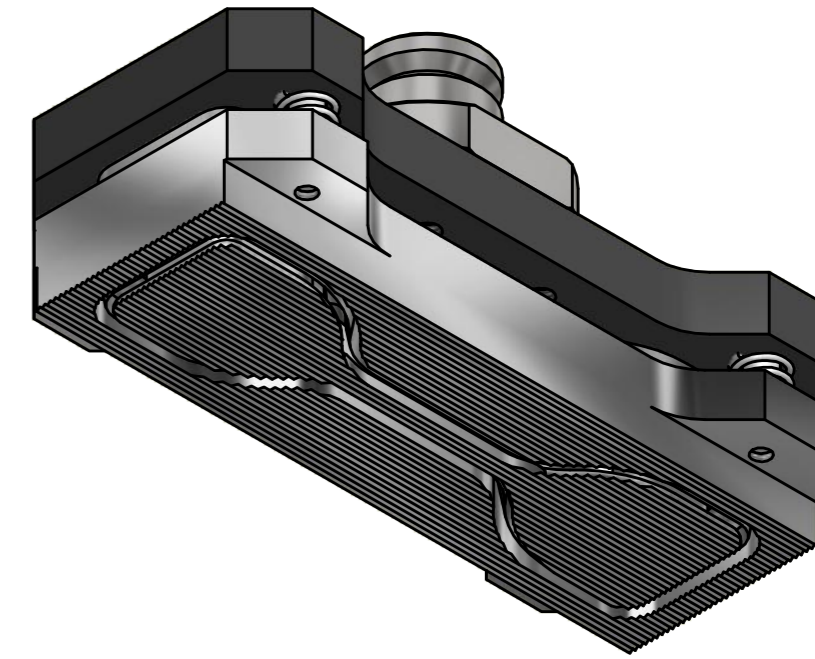

B-B (1:1)

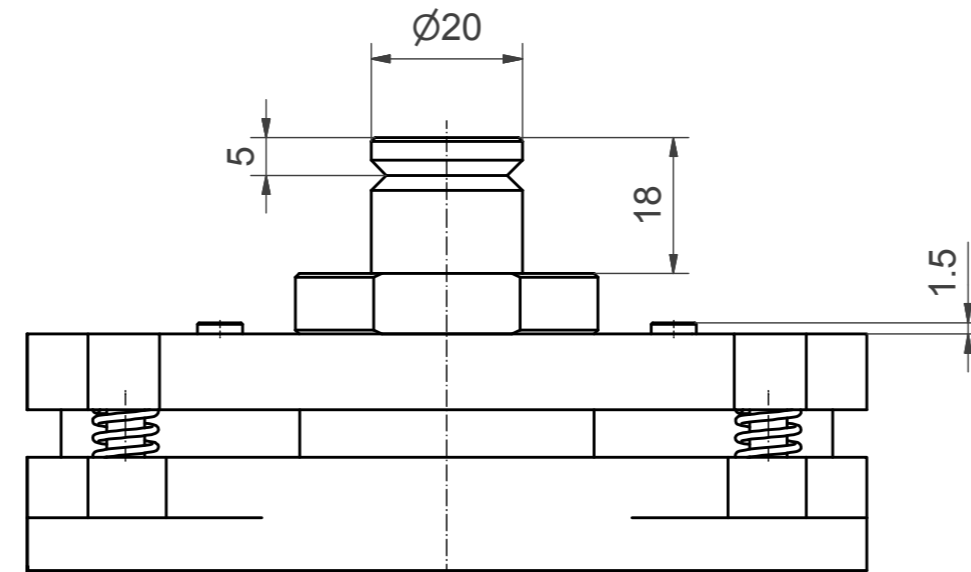
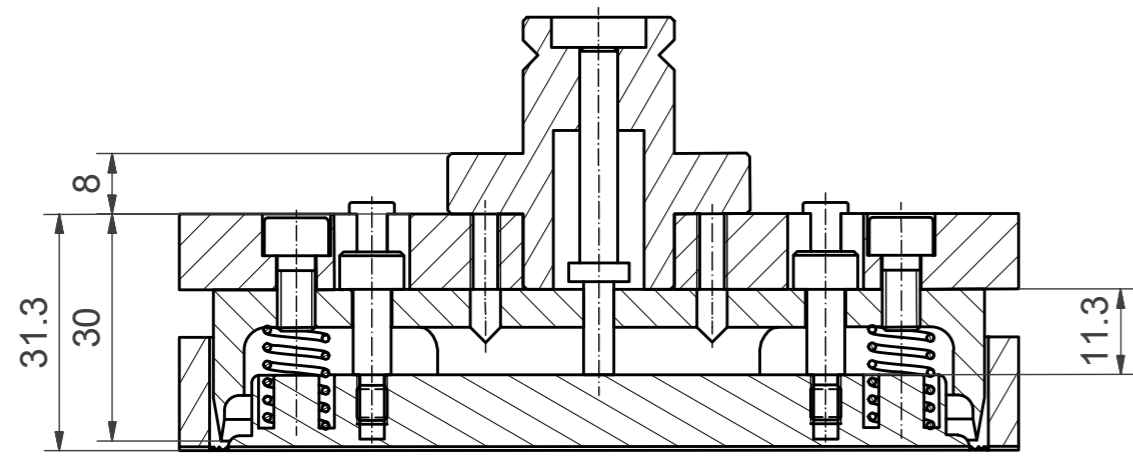
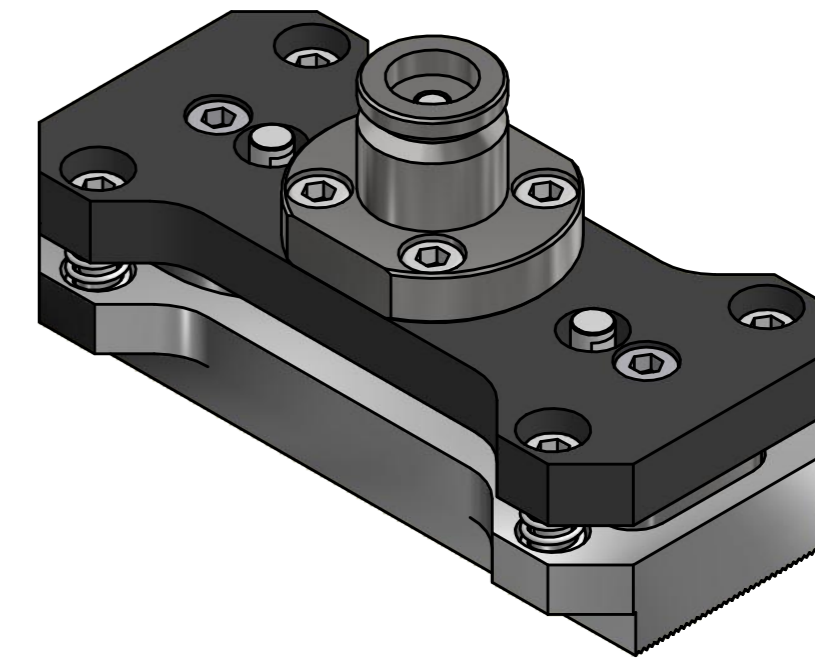
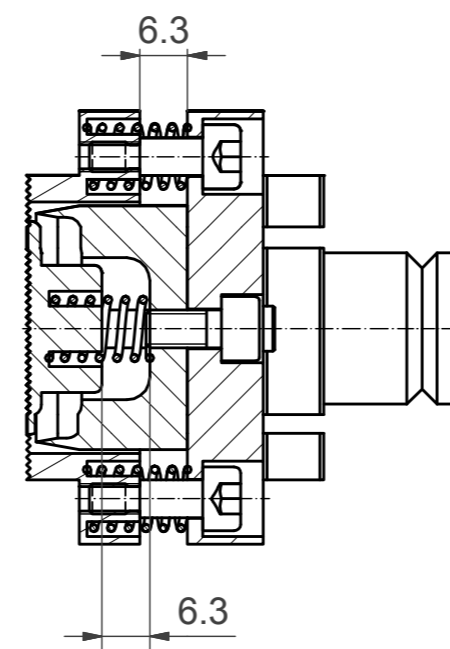
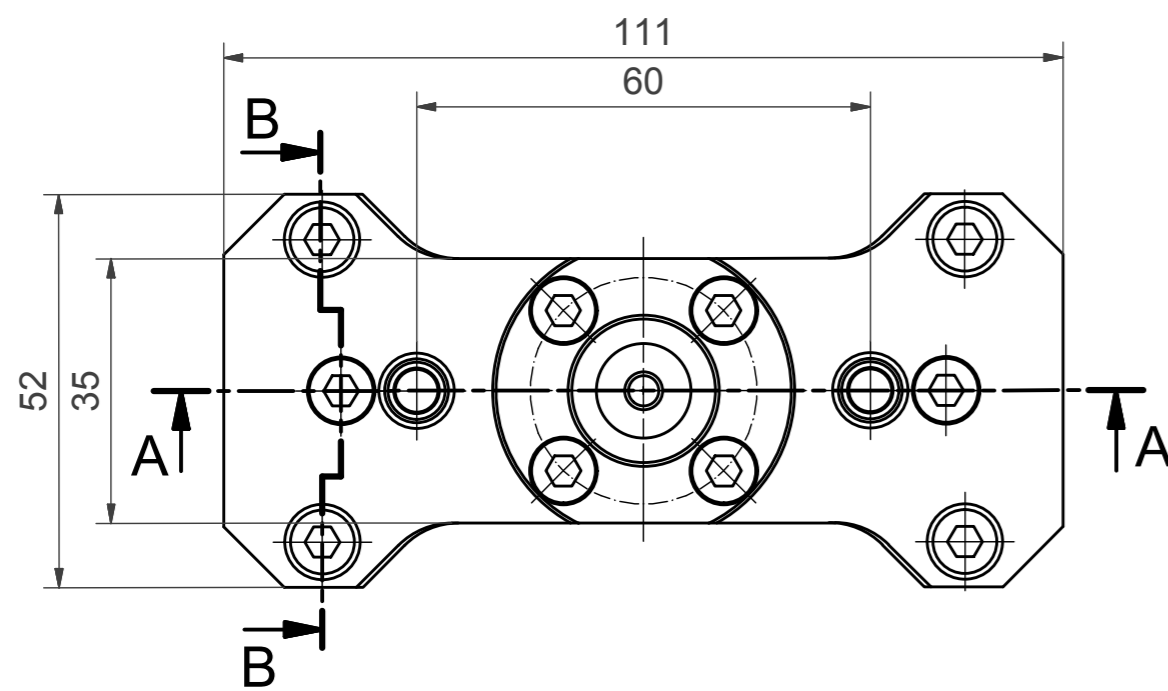

Schutzvermerk nach DIN 34 beachten		Tolerierung ISO 8015		Maßstab: 1:1 Werkstoff: Halbzeug: Rohteil-Nr.:	
		Datum: 21.07.2014 Name: orothenaicher		Stanzmesser-Einheit S1A 31.3x52x111 Normstab S1A DIN 53504 Stanzmesser-Einheit STAM.01.19	
		Gepr.: Norm:			
		Büro für CA-Technik Otto Rothenaicher		STAM.01.19.01.00 Blatt 1	
		Zust. Änderungen Datum Name		St.-Nr.: STAM.01.19.01.00 Ers. f.: Ers. d.: Dateiname: Stanzmesser-Einheit S1A01.iam 1 Bl A2	