

A-A (2:1)

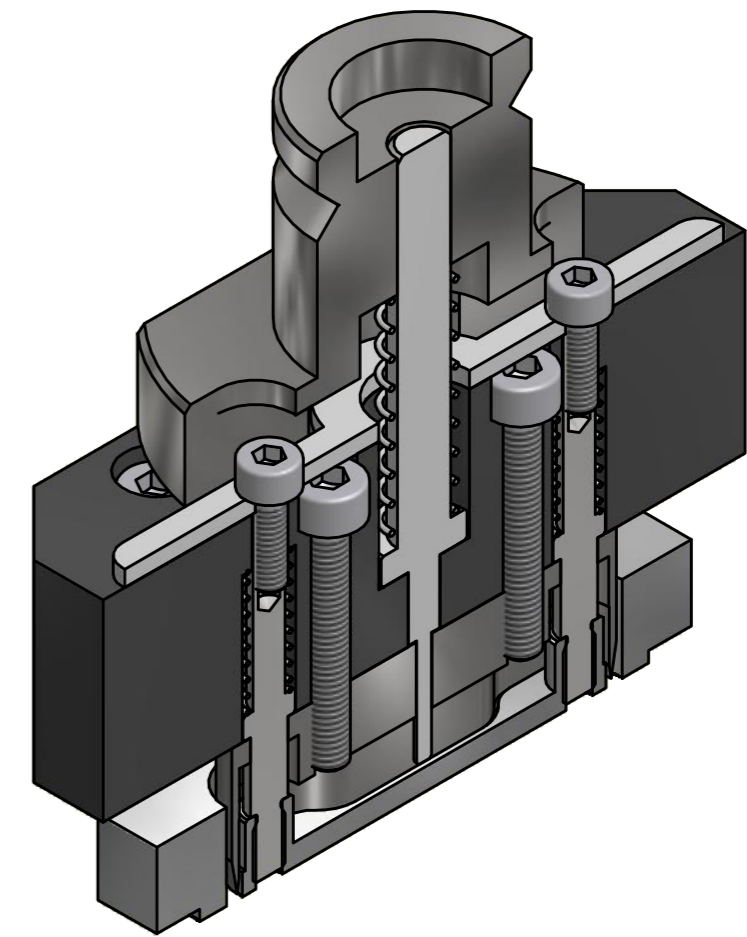
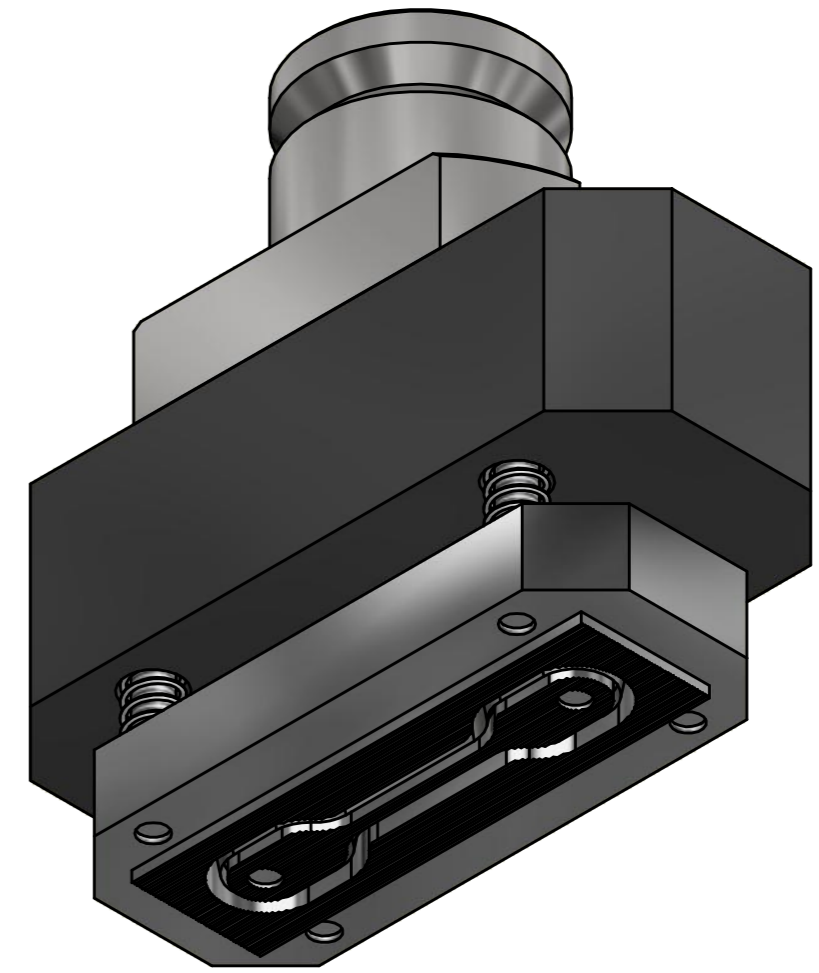
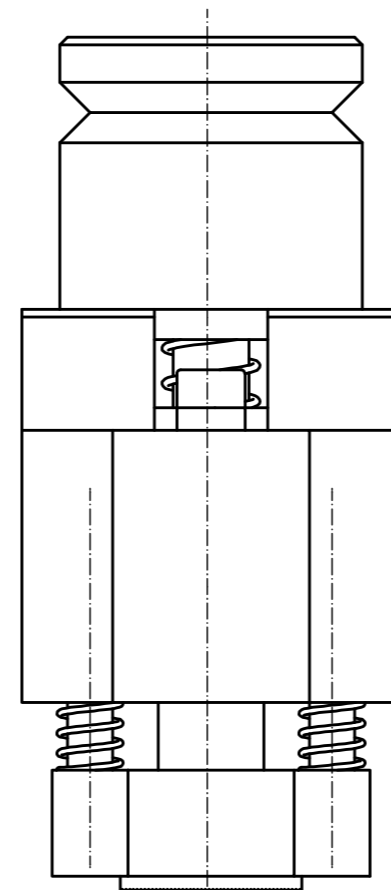
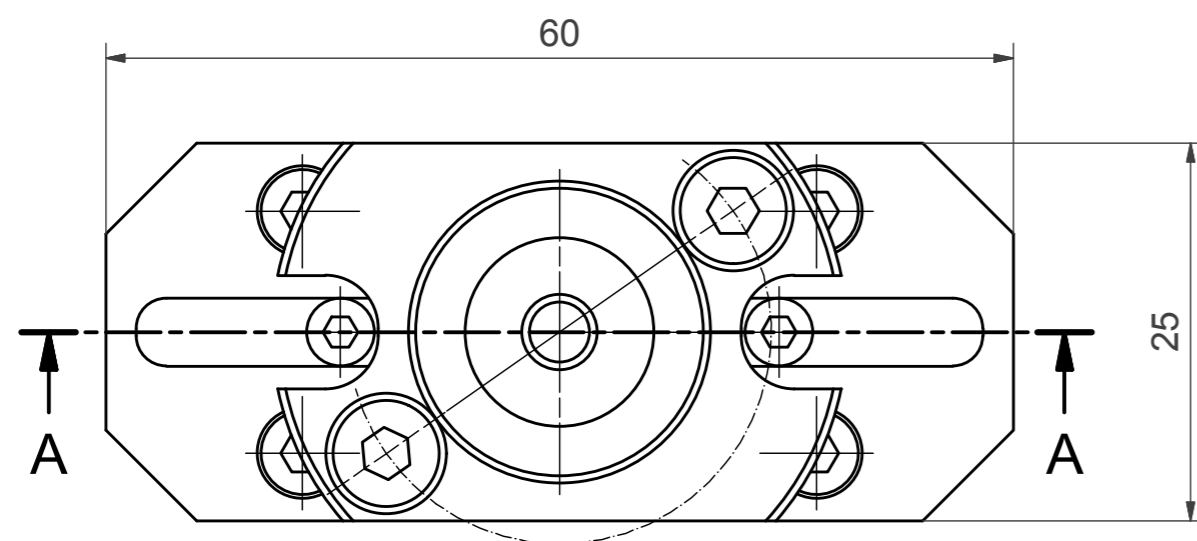
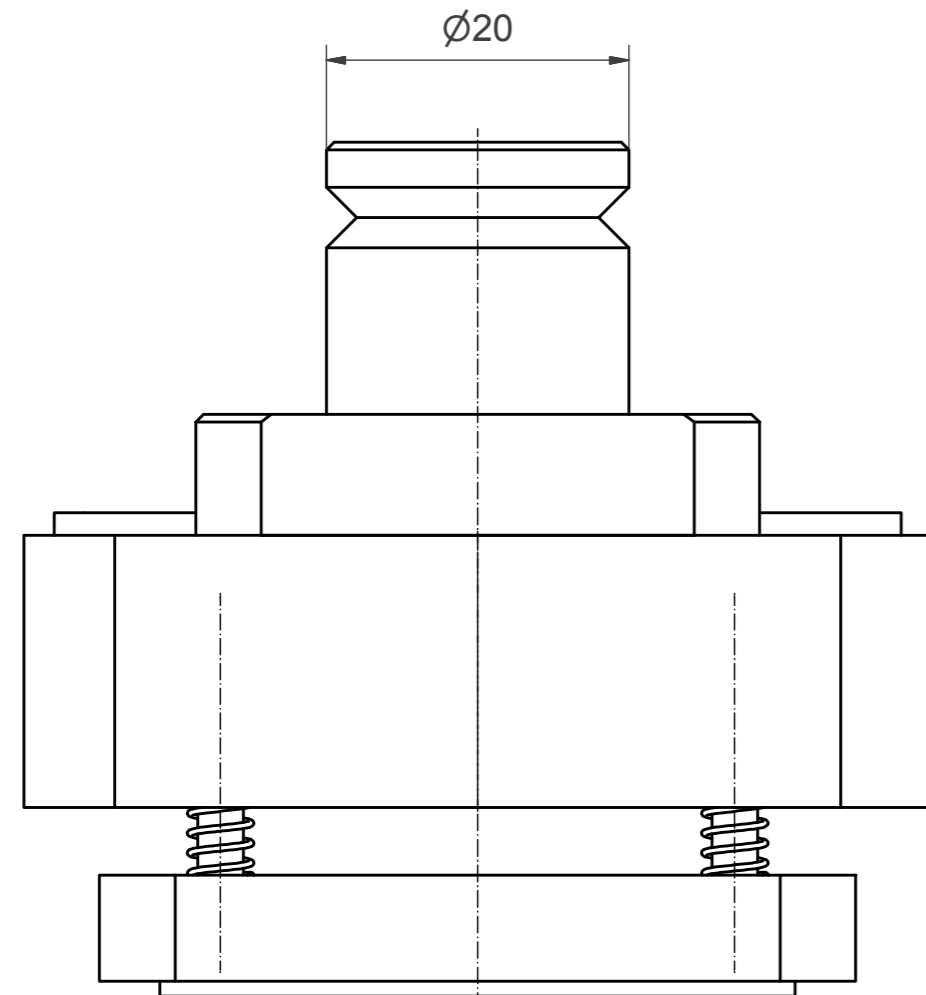
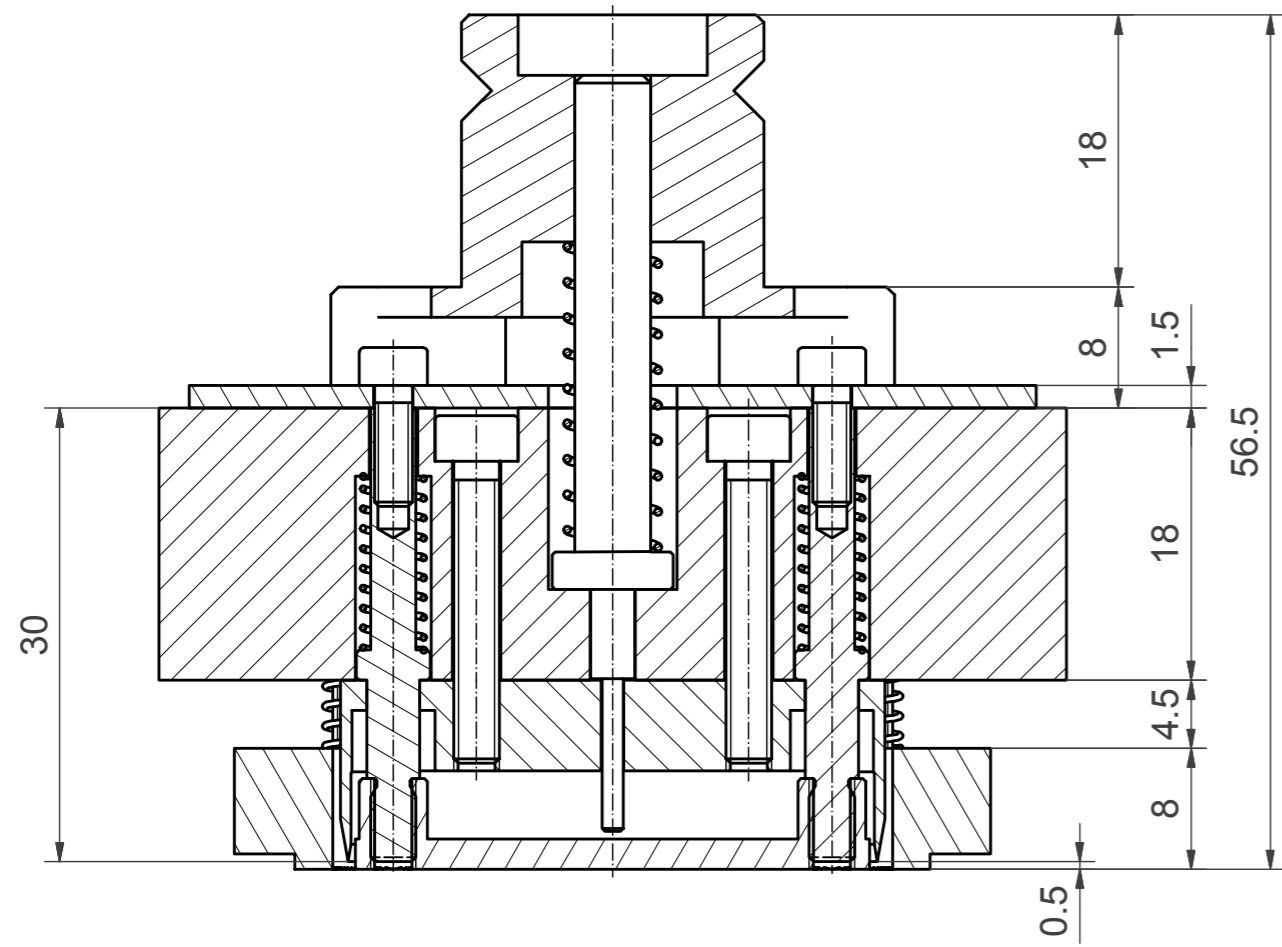

Schutzvermerk nach DIN 34 beachten		Tolerierung ISO 8015		Maßstab: 2:1		Masse:	
				Werkstoff:			
				Halbzeug:			
				Rohteil-Nr.:			
		Datum		Name		Stanzmesser-Einheit S3 30.5x25x60 Normstab S3 DIN 53504 Stanzmesser-Einheit STAM.01.03	
		Gez. 24.06.2013		orothenaicher			
		Gepr.					
		Norm					
				CAD/CAM/CAE Büro für CA-Technik Otto Rothenaicher		STAM.01.03.01.00 Blatt 1	
				St.-Nr.: STAM.01.03.01.00		1 Bl.	
				Ers. f.:		Ers. d.:	
				Dateiname: Stanzmesser-Einheit S301.iam		A2	
Zust.	Anderungen	Datum	Name				